

INSTRUCTION MANUAL

ZVF Pneumatic Butterfly Valve

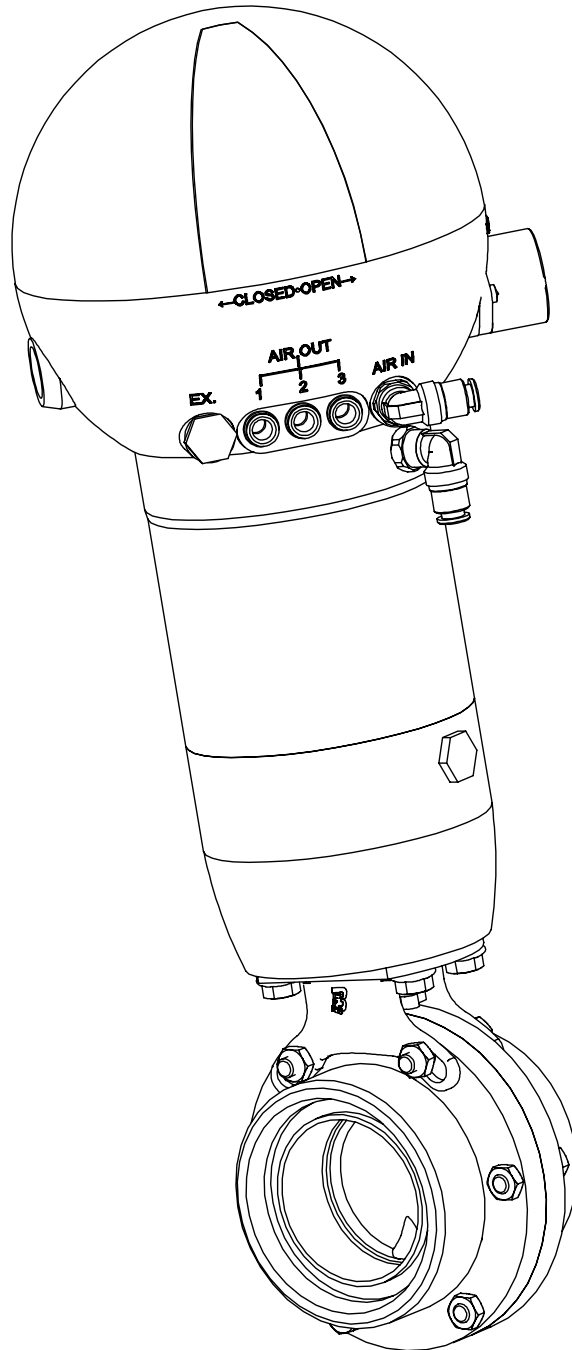

BARDIANI
VALVOLE

1. Safety signs	3
2. General safety precautions	3
3. Receiving/Unpacking/Storage	4
4. Installation	5
5. Operation	7
6. Troubleshooting	8
7. Cleaning	9
8. General maintenance	10
9. Planned maintenance	11
10. Spare parts ordering	12
11. Disassembly of valve type ZVF (DN15--100)	13
Drawings ZVF (DN15--100)	15
12. Assembly of valve type ZVF (DN15--100)	16
13. Disassembly of valve type ZVF (DN125--150)	18
Drawings ZVF (DN125--150)	20
14. Assembly of valve type ZVF (DN125--150)	21
15. Assembly/Disassembly shaft stroke limiter	23
16. Parts list	24
17. Technical data	25
Warranty	26
Disclaimer	26

Foreword

This instruction manual is an integral part of the valve delivery.

- **Always read it carefully before using the valve.**
- **Always keep it for future reference.**

All rights are reserved. It is forbidden to reproduce or transit any part of the instruction manual by any means, either electronic or mechanical, including photo copies, recording or any other memorisation or retrieval system for purposes other than the exclusively personal use by the purchaser – without prior written permission by the manufacturer.

This instruction manual is expressly intended for use by technicians. Therefore, some information which can easily be inferred by reading the text and examining the illustrations and drawings has not been further specified. The publisher is not responsible for any consequences of incorrect operations by the user.

The data and information in this instruction manual are subject to modifications or updates without any further notice or obligations on the part of the manufacturer.

1. Safety/Caution Signs



General WARNING sign, which indicates that special instructions **MUST** be followed to avoid serious personal injuries.



General CAUTION sign, which indicates that special instructions **MUST** be followed to avoid damage of equipment and environment.

NOTE!

Indicates **IMPORTANT** information, which improves the understanding of the instructions.

2. General Safety Precautions



ALWAYS read the technical data before installation, operation and maintenance.

ALWAYS use authorised personal to install, operate and service the valve. The personal should know the valve and the instruction manual thoroughly.

ONLY use the valve for the designed purpose.

ALWAYS handle heavy valves carefully and use lifting tools where necessary.

ALWAYS pay attention to possible loose valve parts when unpacking the delivery.

ALWAYS connect air supply carefully and disconnect after use.

ALWAYS connect electrical supply carefully and disconnect after use.

NEVER touch moving valve parts.

NEVER touch a hot valve.

ALWAYS handle cleaning agents carefully.

NEVER remove a valve from piping or disassemble it when the valve or piping are pressurised.

**We cannot be held responsible for incorrect installation,
operation and maintenance!**

3.Receiving/Unpacking/Storage

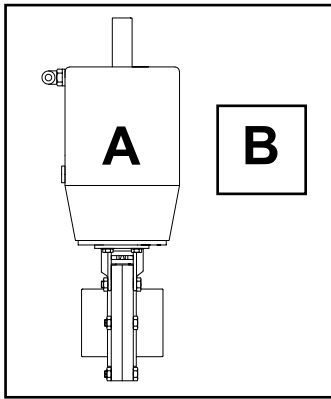

1. UNPACK AND CHECK VALVE DELIVERY:

- A. Complete valve
- B. Instruction manual

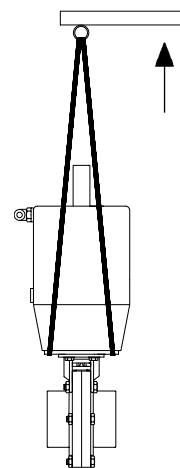

2. LIFTING OF HEAVY VALVE:

- Use lifting tool, if necessary.
- Fix valve to lifting tool.
- Lift valve carefully.

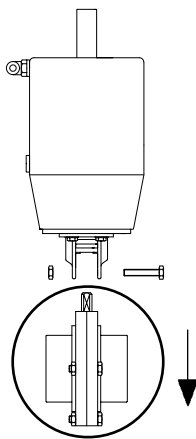

3. HANDLING OF LOOSE VALVE PARTS:

- Avoid falling loose valve parts.
- Assemble and tighten loose parts.
- See assembly instructions.

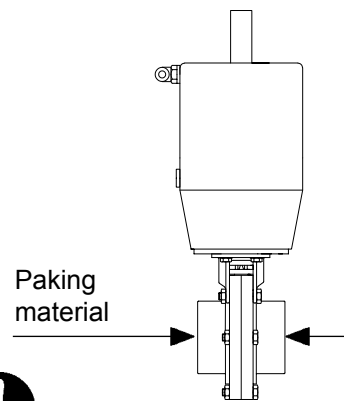

4. PACKING MATERIAL:

- Inspect internal of valve.
- Remove material and dispose of according to current directives.

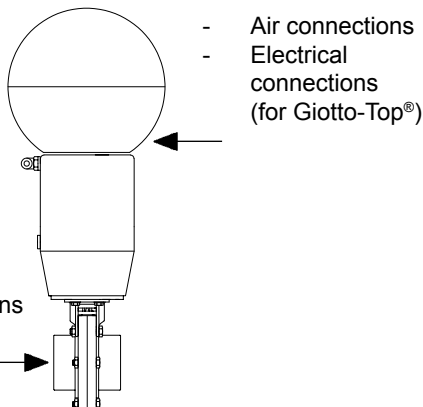

- Opening
- Air connections
- Electrical connections (for Giotto-Top®)



5. INSPECTION/CLAIM:

- Inspect valve connections.
- Document /verify damage, missing or wrong parts.
- Use current claim procedure if necessary.

Safe valve protection!

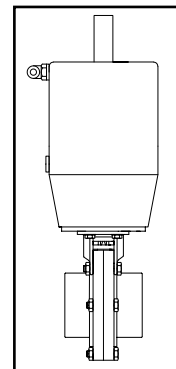

6. STORAGE/PROTECTION:

- Avoid dust, humidity, wet areas, heat and similar.
- Avoid vibration.
- Min.: - 10 °C
- Max.: + 50 °C

4. Installation

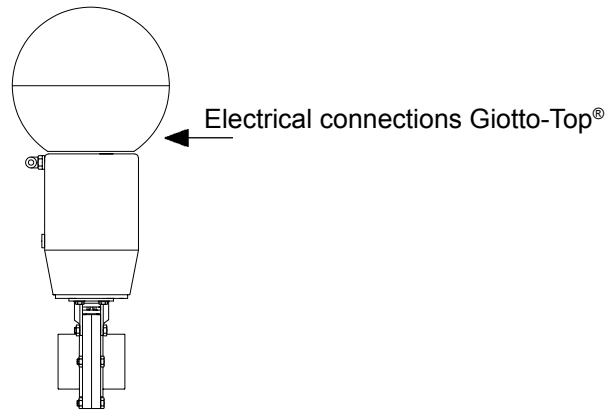

1. CONNECTION OF AIR AND EL SUPPLY:

- Use authorised personnel to install/connect the valve.
- Ensure correct air pressure and quality (see page 23).
- Ensure correct electrical supply for Giotto-Top® (see Giotto-Top® instruction manual).

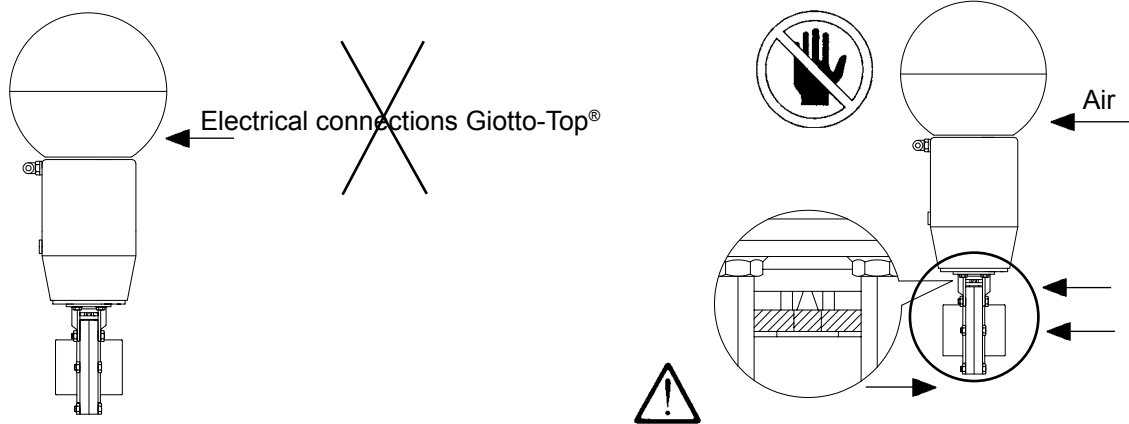

2. DISCONNECT SUPPLIES AFTER USE:

- Disconnect air supply.
- Disconnect electrical supply for Giotto-Top®

3. MOVING VALVE PARTS:

- Never stick fingers into valve ports.
- Never touch moving valve shutter/stem.

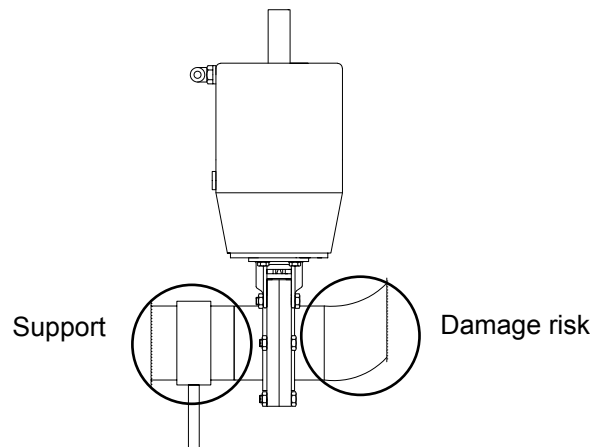

4. AVOID VALVE OVERLOADING AND COMPENSATE FOR:

- Vibration
- Thermal expansion

4. Installation

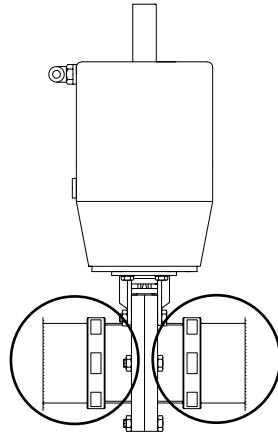

5. VALVE CONNECTIONS/UNIONS:

- Ensure tight connections between valve and piping.
- Remember gaskets and fit correctly.
- Tighten unions firmly and carefully.

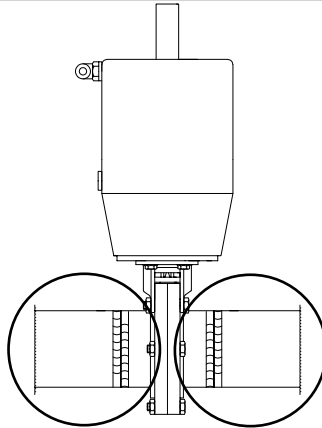

6. WELDING VALVE BODY INTO PIPING:

- Remove inner valve parts.
- Weld body carefully into piping.
- Assemble valve.
- See assembly instructions.

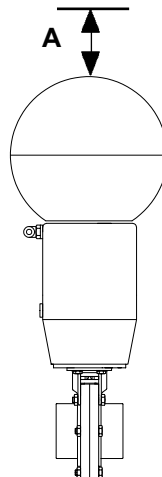

7. INSTALLING VALVE INTO PIPING:

Ensure sufficient clearance for valve disassembly.

5. Operation

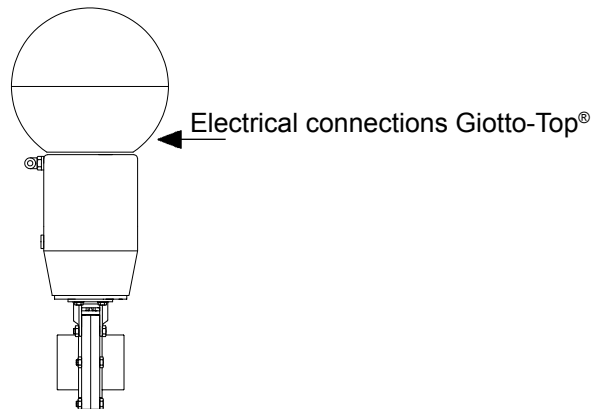

1. CONNECTION OF AIR AND EL SUPPLY:

- Use authorised personnel to install/connect the valve.
- Ensure correct air pressure and quality (see page 24).
- Ensure correct electrical supply for Giotto-Top® (see Giotto-Top® instruction manual).

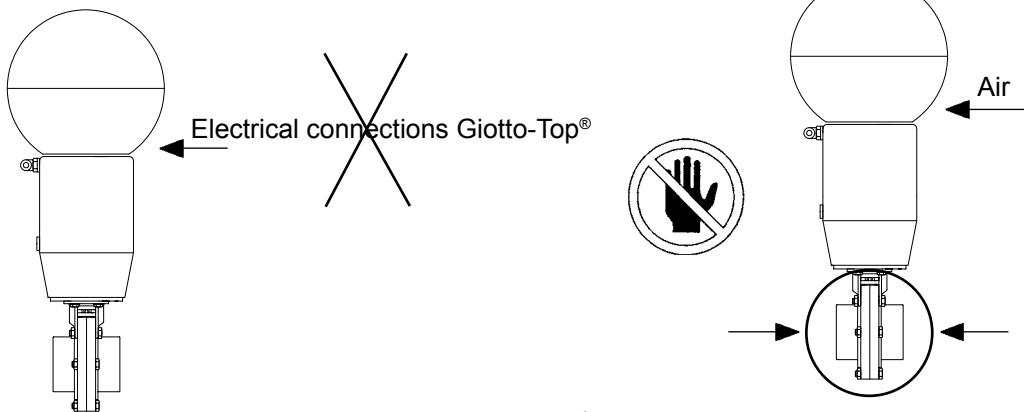

2. DISCONNECT SUPPLIES AFTER USE:

- Disconnect air supply.
- Disconnect electrical supply for Giotto-Top®



3. MOVING VALVE PARTS:

- Never stick fingers into valve ports.



BURNING RISK!

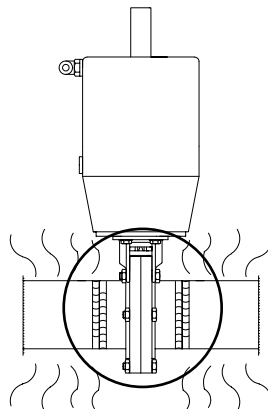

4. HOT VALVE/PIPING:

- Never touch hot valve or piping, if possible.
- Alternatively use protective gloves.

5. Operation

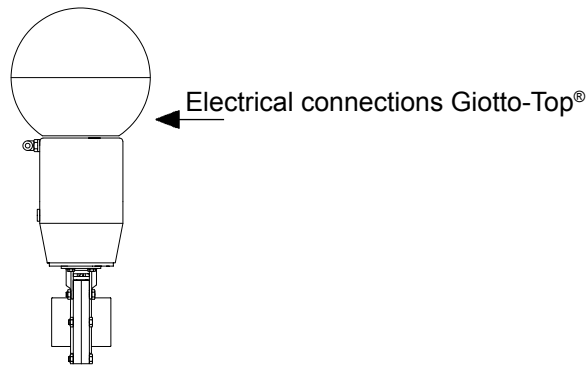

- 5. PRE-USE CHECK VALVE BEFORE OPERATION:**
- Supply air to the valve.
 - Supply el to the valve(with Giotto-Top®).
 - Open and close the valve several times.
 - Check that the valve functions operate correctly and smoothly.



1. TROUBLESHOOTING VALVE:
Always study operation and maintenance instructions carefully before troubleshooting.

Risk of external or internal corrosion!

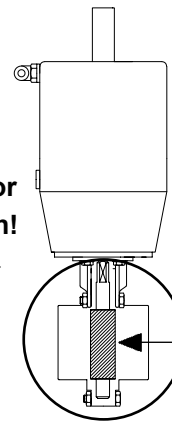

Check and replace gaskets!



- 2. REPLACING WORN VALVE PARTS:**
- See page 13 for spare parts ordering.
 - Dispose of worn parts according to current directives

PROBLEM	POSSIBLE CAUSE	POSSIBLE REMEDY
External leakage	Worn out gasket	Replace gasket
Internal leakage with closed valve, caused by normal wear		
External leakage	Too high pressure	Replace with gasket of different elastomer type
	Too high temperature	
Internal leakage with closed valve occurring earlier than normal wear	Aggressive fluids	Modify operation conditions
	Too many active control	
Difficult opening and closing	Incorrect elastomer type of gaskets	Replace with gasket of different elastomer type
	Incorrect positioning of actuator	Assemble actuator correctly
	Incorrect operation of actuator	Change from normally open (NO) to normally closed (NC) or vice versa
	Dirt in actuator	Check and service actuator
	Incorrect positioning of valve body	Disassemble and reposition valve body

7. Cleaning



1. CLEANING VALVE WITH CLEANING AGENTS:

- Use authorised personnel to clean the valve.
- Observe concentrations of cleaning agents.
- Follow instructions of cleaning agent suppliers.
- Always use protective goggles and gloves.

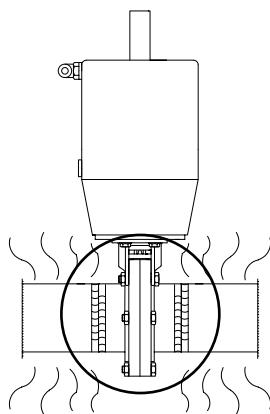

Risk of external or internal corrosion!

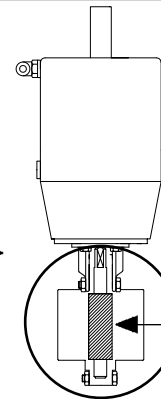

Check and replace gaskets!



2. HOT VALVE/PIPING:

- Never touch hot valve or piping, if possible.
- Alternatively use protective gloves.

3. HANDLING OF CLEANING AGENTS:

- Dose cleaning agents regularly to avoid excessive concentration.
- Always rinse carefully with clean water after cleaning.
- Check compatibility of valve materials.

Example of suggested CIP		
Step	Temperature °C	Cip product
First rinsing	Atmosphere	Water without chlorine or chlorids
Washing	70°	Soda (NaOH) at 1%
Intermediate washing	Atmosphere	Water without chlorine or chlorids
Washing	70°	Nitric acid (HNO3) at 0,5%
Final rinsing	Atmosphere	Water without chlorine or chlorids

Recommended claning speed = 2 m/s

8. General Maintenance

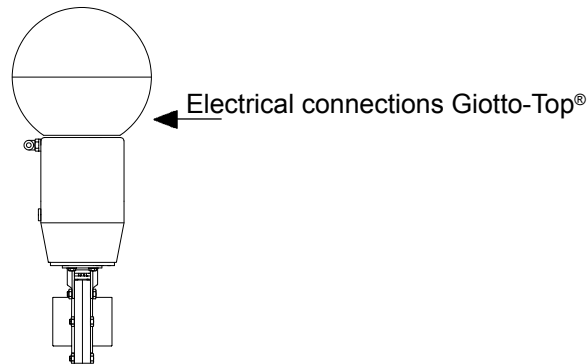

1. CONNECTION OF AIR AND EL SUPPLY:

- Use authorised personnel to install/connect the valve.
- Ensure correct air pressure and quality (see page 23).
- Ensure correct electrical supply for Giotto-Top® (see Giotto-Top® instruction manual).

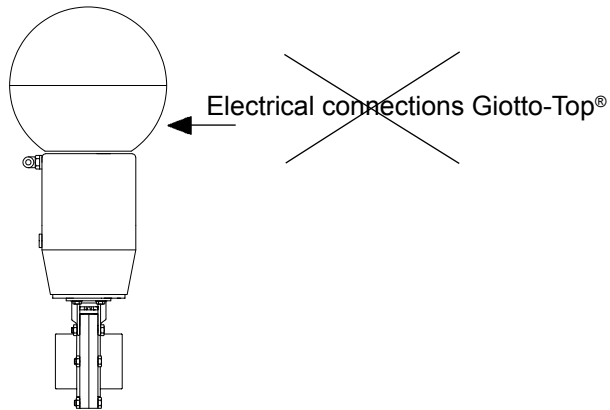

2. DISCONNECT SUPPLIES AFTER USE:

- Disconnect air supply.
- Disconnect electrical supply for Giotto-Top®

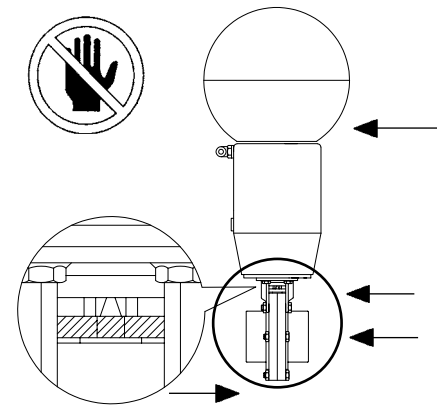

3. MOVING VALVE PARTS:

- Never stick fingers into valve ports.
- Never touch moving valve shutter/stem.

Atmospheric pressure required!

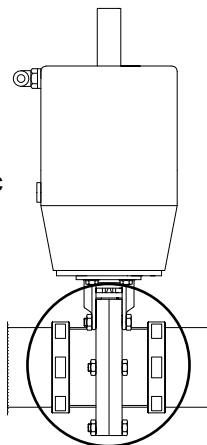

4. PRESSURISED VALVE/PIPING:

Always release fluid pressure from valve and piping before disassembling the valve.



BURNING RISK!



5. HOT VALVE/PIPING:

- Never touch hot valve or piping, if possible.
- Alternatively use protective gloves.

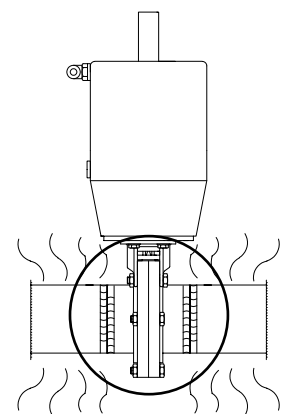

8. General Maintenance

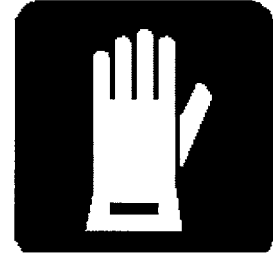
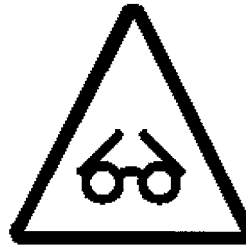
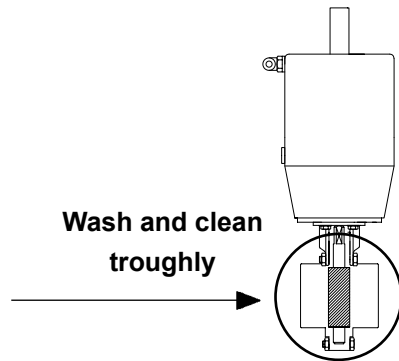

6. CLEANING OF DEPOSITS:

- Wash and clean all valve parts thoroughly before disassembly and assembly!
- Pay attention to possible deposits of cleaning agents and other aggressive fluids!
- Always use protective goggles and gloves, if necessary.



7. REPLACING WORN VALVE PARTS:

- Always use original spare parts.
- See page 13 for spare parts ordering.
- Dispose of worn parts according to current directives.

9. Planned Maintenance

Planned maintenance	Valve gaskets	Actuator gaskets
Preventive	Replace after 12 months	Replace after 24 months
In case of leakage	Replace at the end of the day	Replace in case of leakage
Periodical	Check for correct operation and absence of leakage	Check for correct operation and absence of leakage
	Record all actions taken	Record all actions taken

10. Spare Parts Ordering



NOTE!

Please copy this page, fill it out and fax it to below address.

TO:
BARDIANI VALVOLE S.P.A. – Ufficio Ricambi
Fax: +3905253408

From:			
Valve type:			
Serial number:			
Month/Year of purchase:			
Shipping instructions:			
Quantity:		Position no.:	
Description:			
Quantity:		Position no.:	
Description:			
Quantity:		Position no.:	
Description:			
Quantity:		Position no.:	
Description:			

11. Disassembly of valve type ZVF (DN15--100)

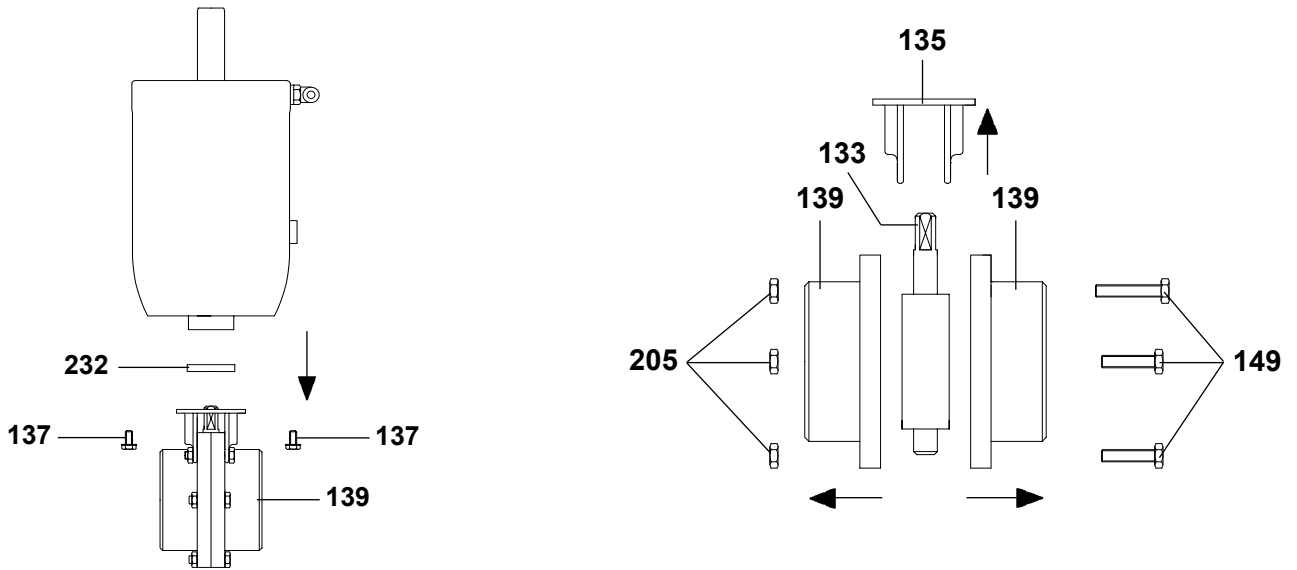

1. Remove the body (139) and butterfly indicator (232) having unscrewed the bolts (137). Dispose of worn parts according to current directives.

2. Remove the bolts (149) and nuts (205) in order to open the two parts of the body (139) and remove the butterfly (133) and its support (135).

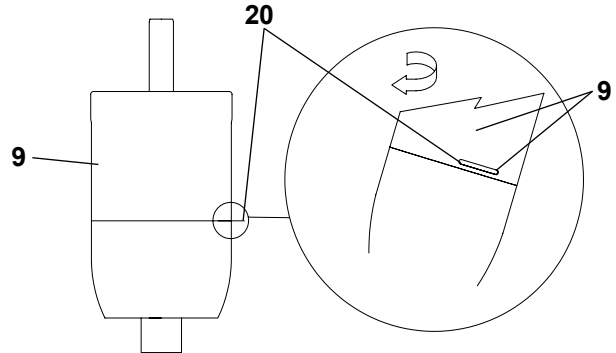
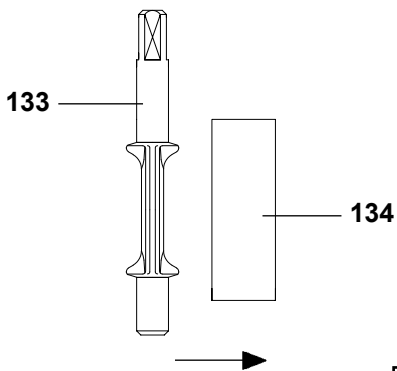

3. Remove the seal/gasket (134) from the butterfly (133).

4. Unscrew the shaft (23) of the cylinder (9). Lock wire (20) by rotating the cylinder (9) until the end of the wire (20) is no longer visible through the cylinder slot (9). Remove completely the end part using a pointed tool.

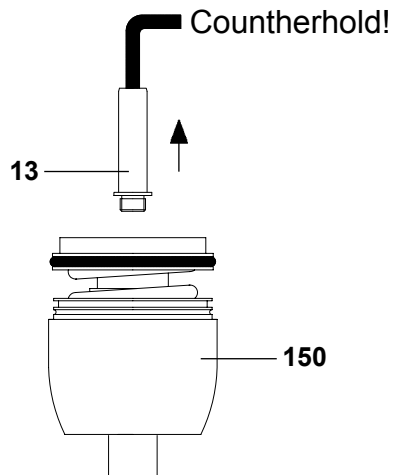
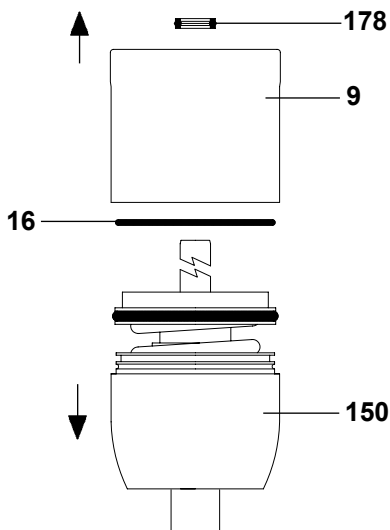

5. Remove the sealing ring (178), the cylinder (9) and the sealing ring (16) from the plug (150).

6. Unscrew the shaft (23) from the plug (150). Counterhold the shaft with an allen wrench.

11. Disassembly of valve type ZVF (DN15--100)

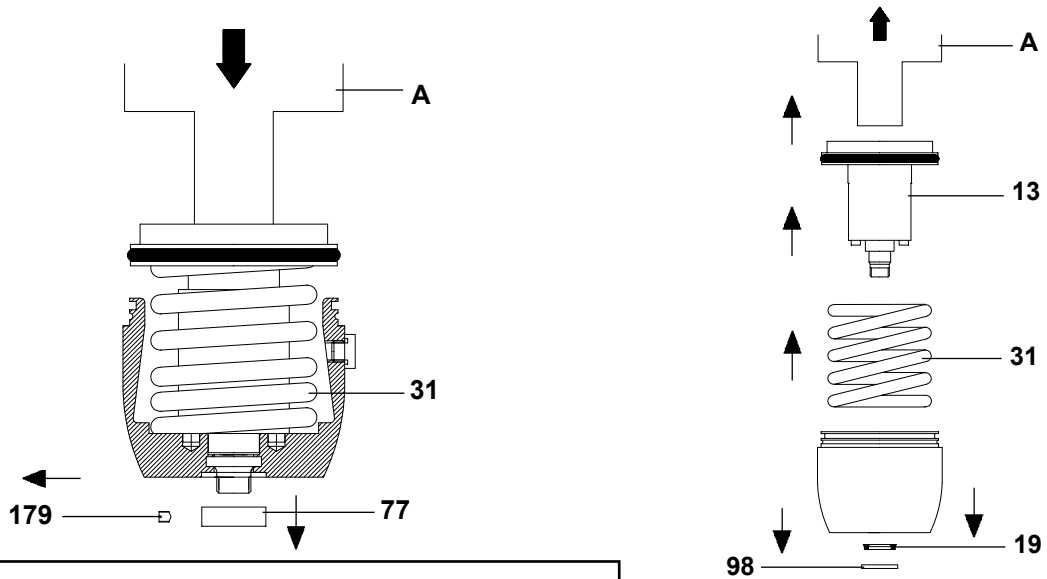

7. Using a press or special tool (A) compress the spring a few millimetres (31).



This operation must be carried out with great care by a specialised technician.

Remove the grub screw (179) and unscrew the ring nut (77).

8. Having carefully reduced the pressure exerted on the special tool (A) by the spring (31), remove the piston (13) and the spring itself (31). Remove the washer (98), the seal (19).

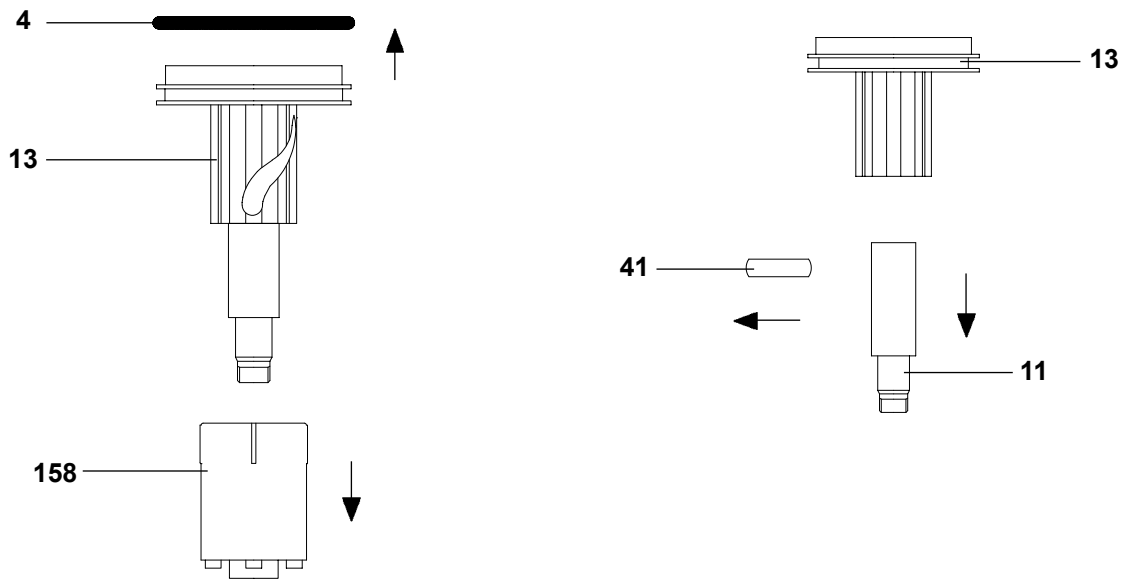

9. Remove the sealing (4) and tube (158) from the piston (13).

10. Remove the pin (41) and slide out the shaft (11) from the piston (13).

11. Disassembly of valve type ZVF (DN15--100)

ZVF Pneumatic Butterfly (DN15--100)

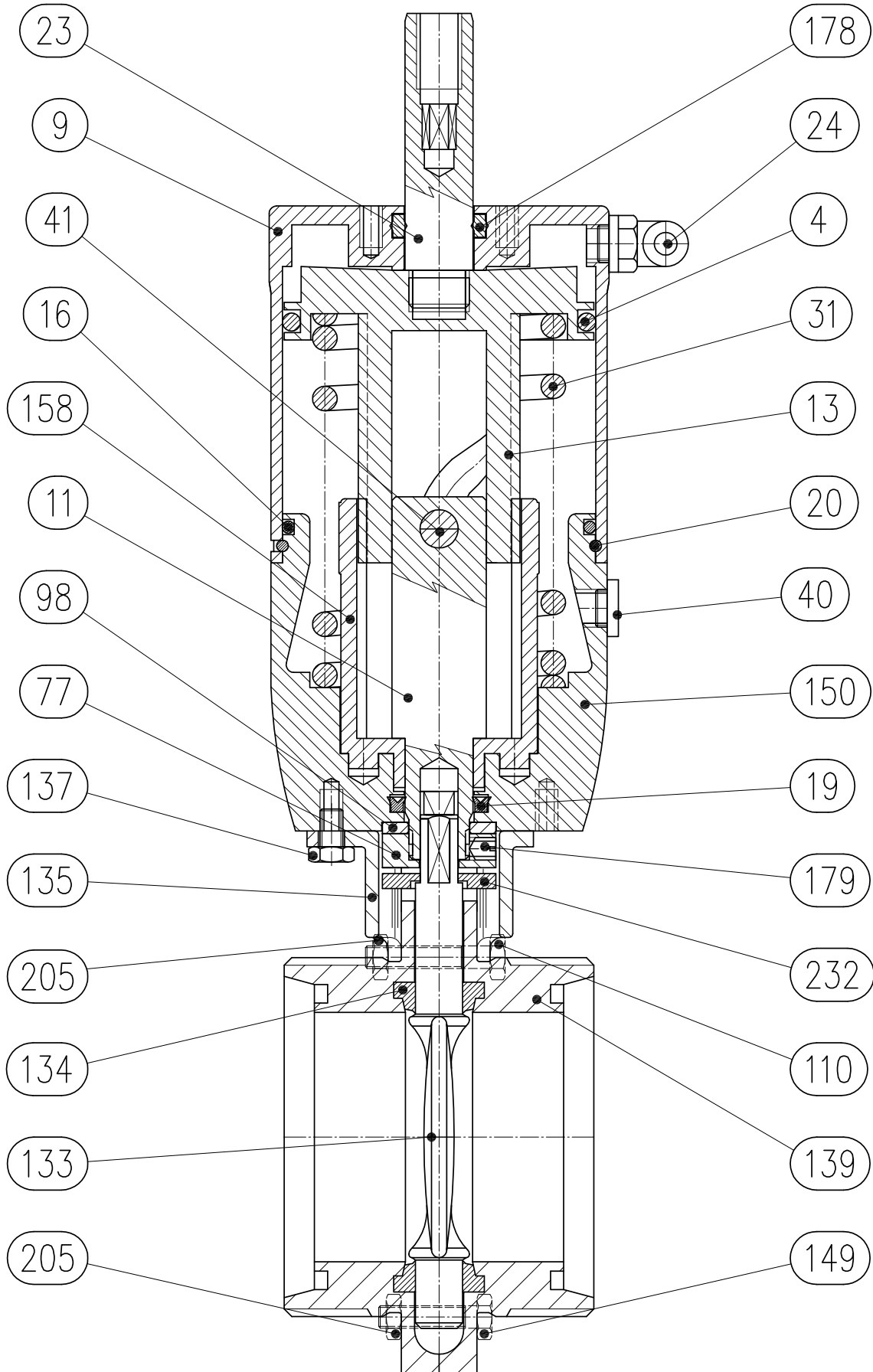

12. Assembly of valve type ZVF (DN15--100)

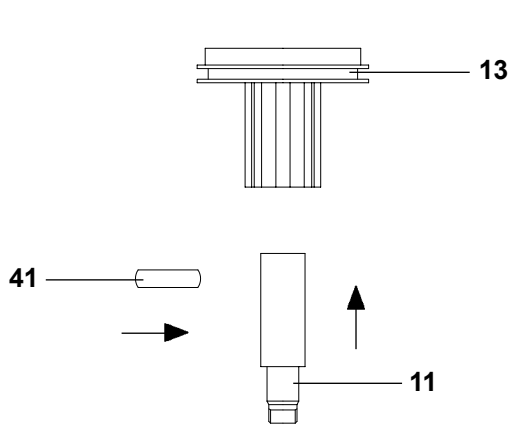

1. Fit the shaft (11) on the piston (13) and insert locking pin (41).

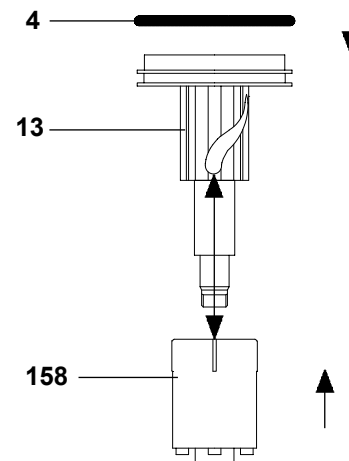

2. Fit the sealing ring (4) and tube (158) on the piston (13).

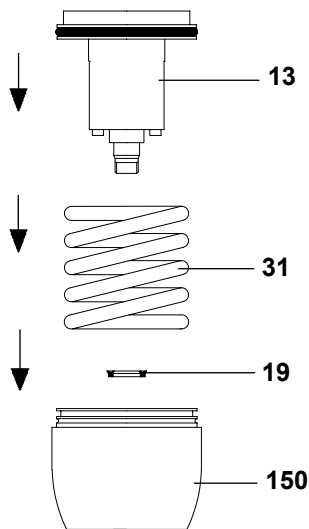

3. Fit in the following order the seal (19), the spring (31) and the piston (13) in the plug (150).

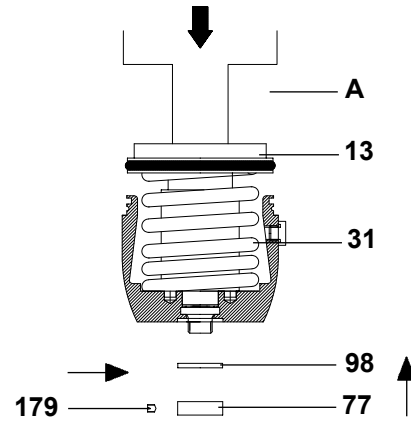

4. Using the special tool (A) compress the piston (13) as indicated in the above diagram so the spring (31) closes. Fit the washer (98) and tighten the ring nut (77).
N.B. The ring nut must be tightened up to its seat but do not over tighten.
 Finally lock the whole assembly tightening the grub screw (179) and with caution remove the special tool (A).

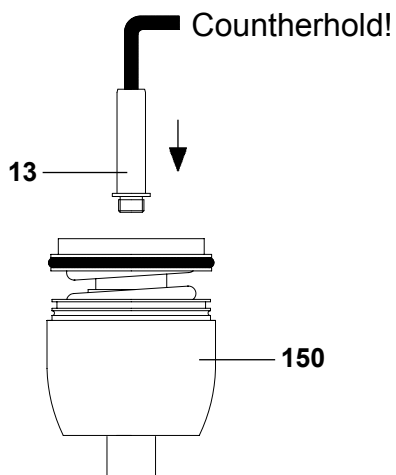

5. shaft (23) into the plug (150). Counterhold the pivot with an allen wrench.

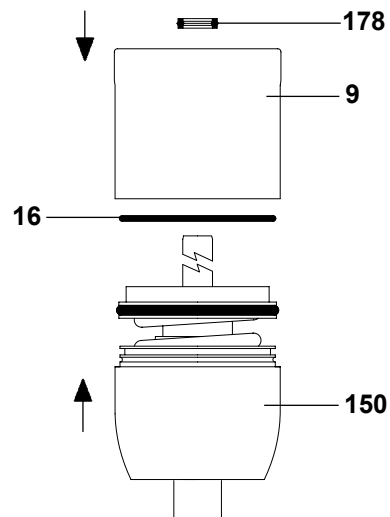

6. Fit in the following order the sealing ring (16), plug (150), the cylinder (9) and sealing ring (178).

12. Assembly of valve type ZVF (DN15--100)

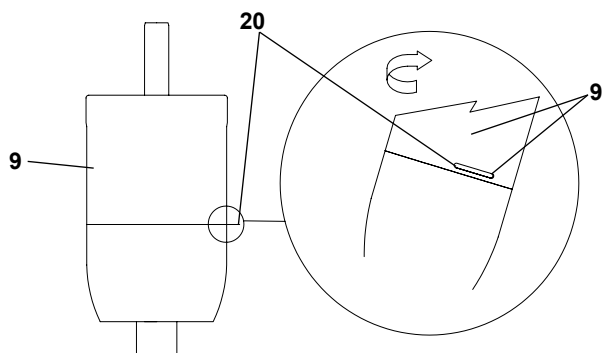

7. Fit the lock wire (20) in the plug (150) through the slot in the cylinder (9). Rotate the cylinder (9) until the wire (20) is completely inserted, tighten the shaft (23) on the cylinder (9).

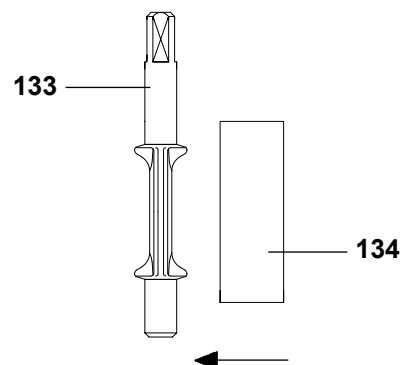

8. Insert the seal/gasket (134) on the butterfly (133).

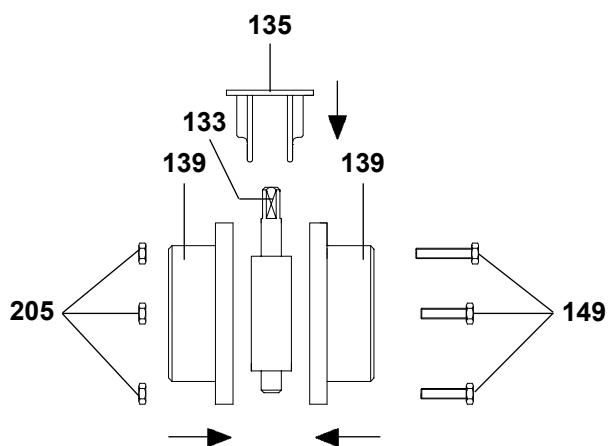

9. Fit the two halves of the body (139) inserting the butterfly (133). Tighten all parts including the support (135) with the bolts (149) and nuts (205).

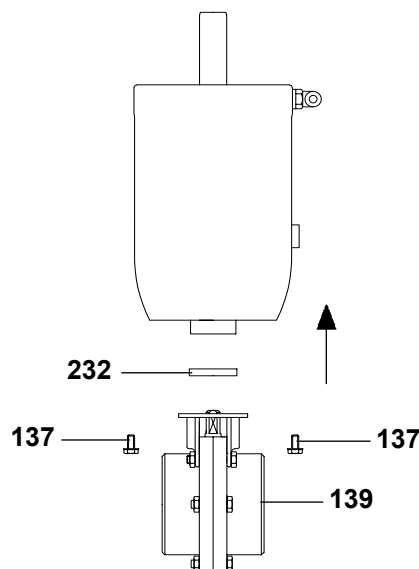

10. Fit the valve body (139) on the actuator remembering to insert the butterfly indicator (232). Close and tighten bolts (137).

13. Disassembly of valve type ZVF (DN125-150)

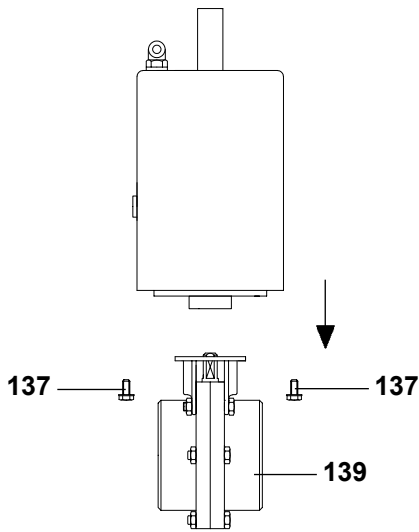

1. Remove the body (139) having unscrewed the bolt (137).

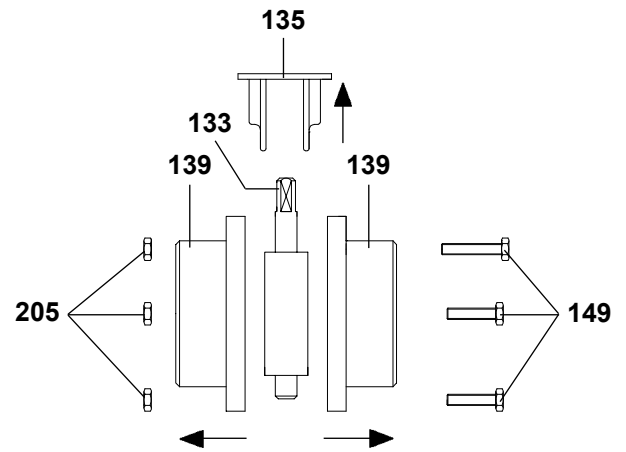

2. Remove the bolts (149) and nuts (205) in order to open the two parts of the body (139) and remove the butterfly (133) and its support (135).

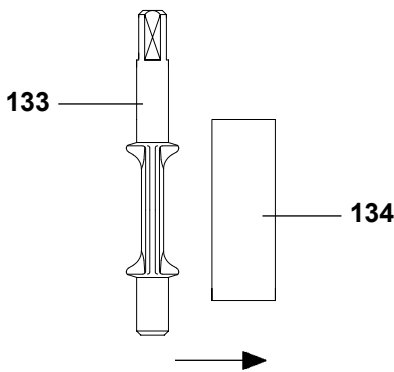

3. Remove the seal/gasket (134) from the butterfly (133).

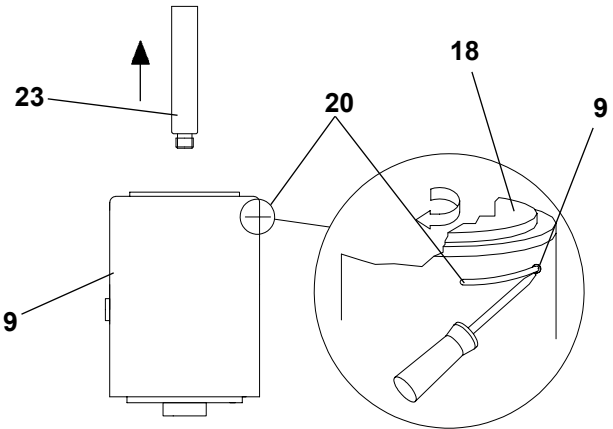

4. Unscrew the shaft (23) of the cylinder (9). Lock wire (20) by rotating the plug (18) until the end of the wire (20) is no longer visible through the cylinder slot (9). Remove completely the end part using a pointed tool.

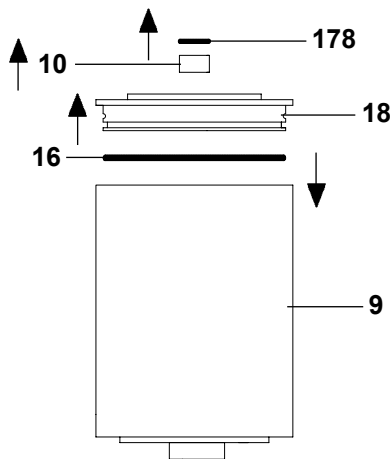

5. Remove the sealing ring (178), the bush (10), the plug (18) and the sealing ring (16) from the cylinder (9).

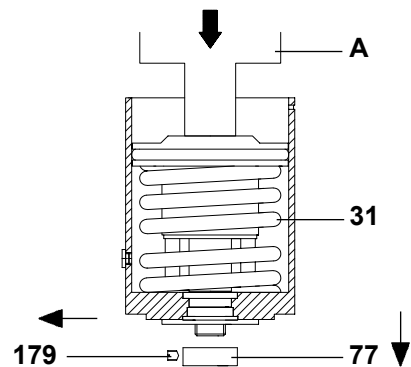

6. Using a press or special tool (A) compress the spring a few millimetres (31). **This operation must be carried out with great care by a specialised technician.** Remove the grub screw (179) and unscrew the ring nut (77).

13. Disassembly of valve type ZVF (DN125-150)

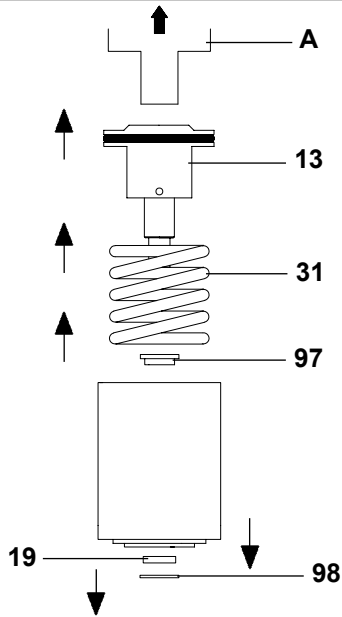

7. Having carefully reduced the pressure exerted on the special tool (A) by the spring (31), remove the piston (13) and the spring itself (31). Remove the washer (98), the seal (19) and the bush (97).

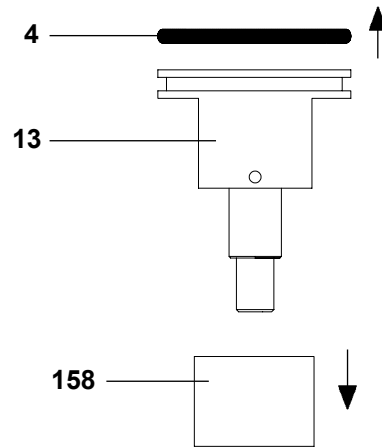

8. Remove the sealing (4) and tube (158) from the piston (13).

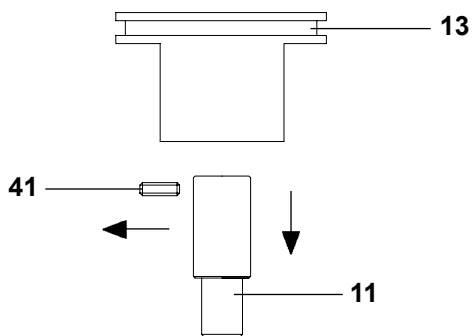

9. Remove the pin (41) and slide out the shaft (11) from the piston (13).

13. Disassembly of valve type ZVF (DN125-150)

ZVF Pneumatic Butterfly (DN125--150)

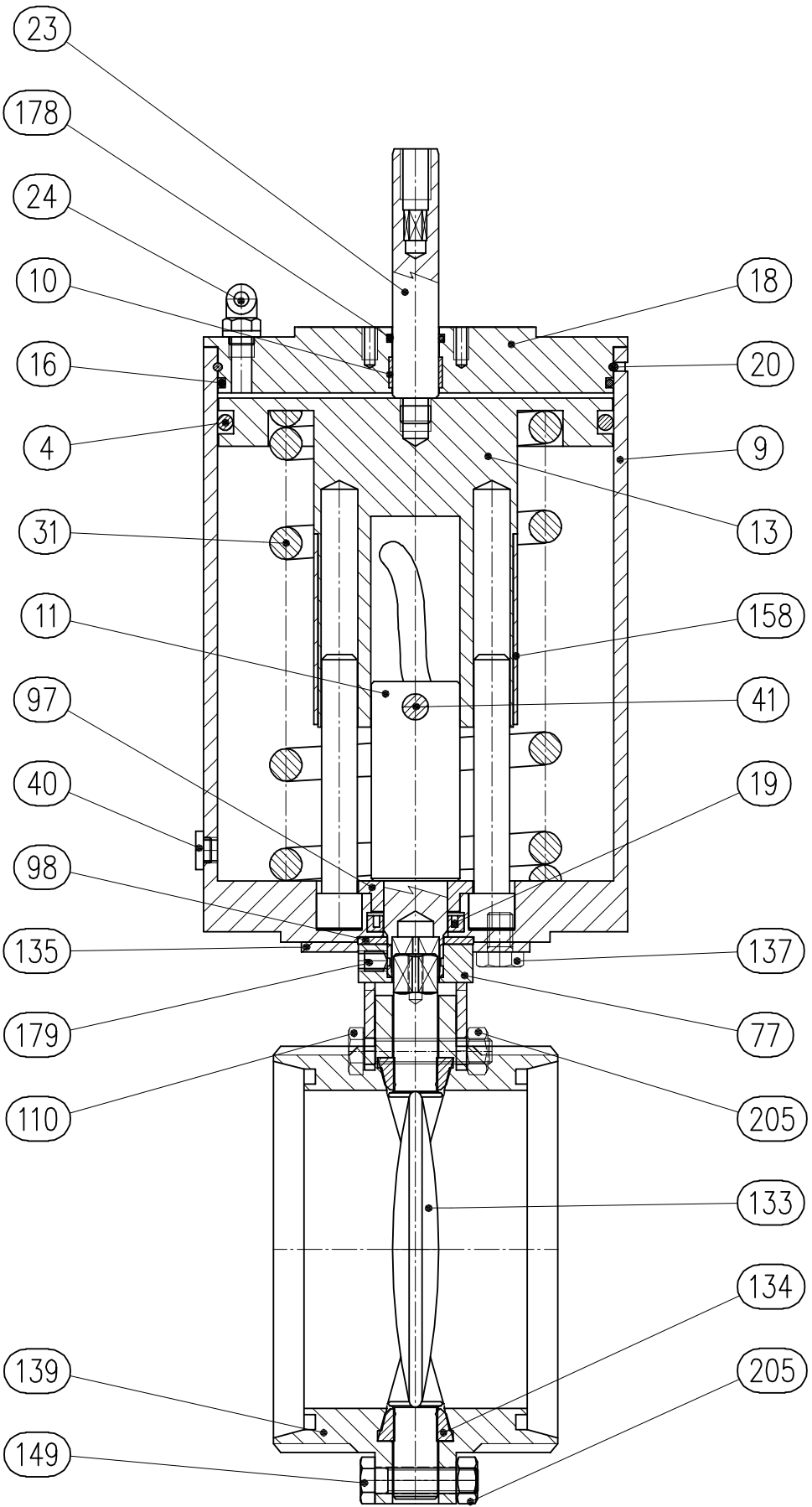

14. Assembly of valve type ZVF (DN125--150)

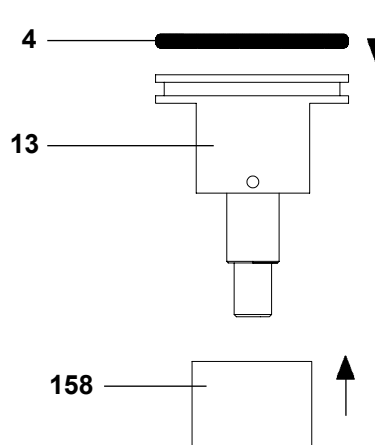
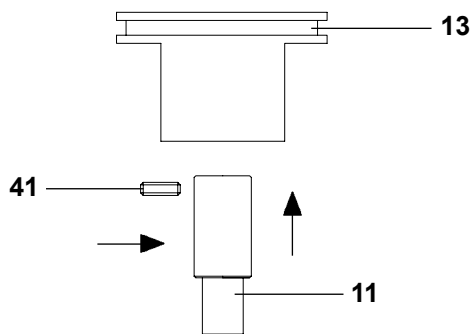

1. Fit the shaft (11) on the piston (13) and insert locking pin (41).

2. Fit the sealing ring (4) and tube (158) on the piston (13).

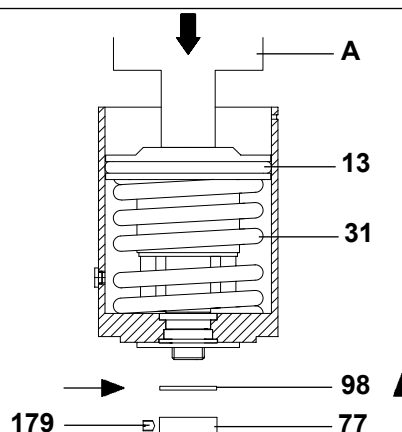
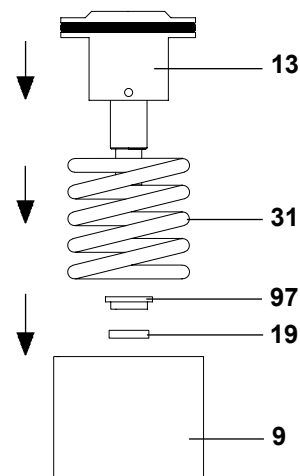

3. Fit in the following order the seal (19), the bush (97), the spring (31) and the piston (13) in the cylinder (9).

4. Using the special tool (A) compress the piston (13) as indicated in the above diagram so the spring (31) closes. Fit the washer (98) and tighten the ring nut (77).
N.B. The ring nut must be tightened up to its seat but do not over tighten.
 Finally lock the whole assembly tightening the grub screw (179) and with caution remove the special tool (A).

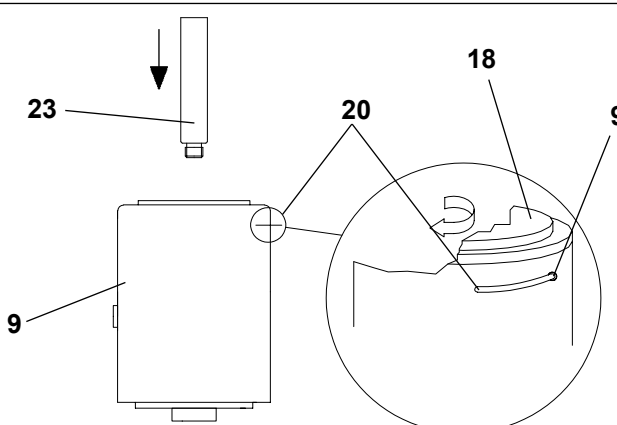
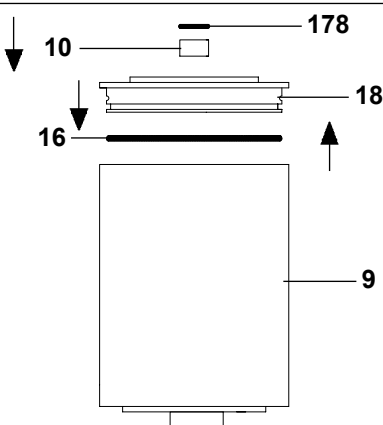

5. Fit in the following order the sealing ring (16), plug (18), bush (10) and sealing ring (178).

6. Fit the lock wire (20) in the plug (18) through the slot in the cylinder (9). Rotate the plug (18) until the wire is completely inserted, tighten the shaft (23) on the cylinder (9).

14. Assembly of valve type ZVF (DN125--150)

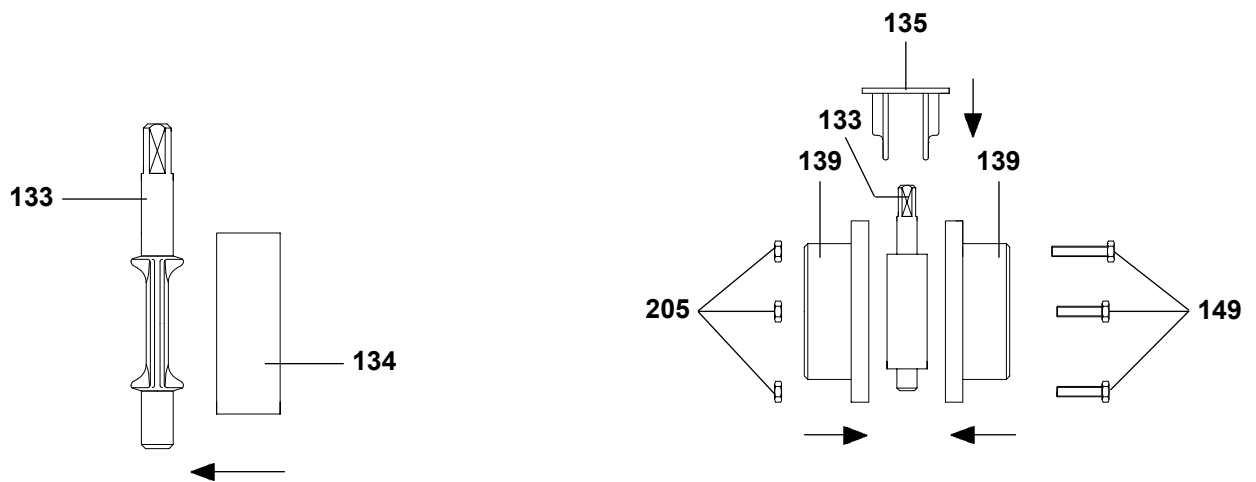

7. Insert the seal/gasket (134) on the butterfly (133).

8. Fit the two halves of the body (139) inserting the butterfly (133). Tighten all parts including the support (135) with the bolts (149) and nuts (205).

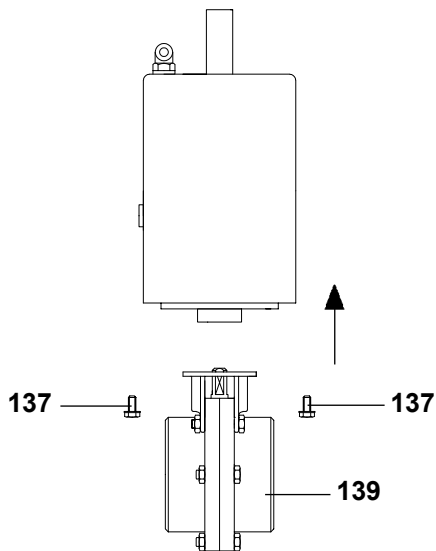

9. Fit the valve body (139) on the actuator. Close and tighten bolts (137).

15. Assembly/Disassembly shaft stroke limiter

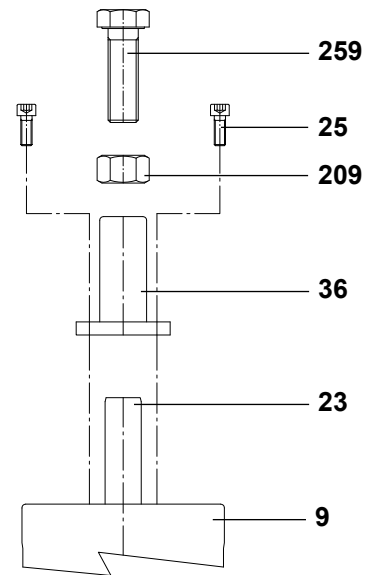
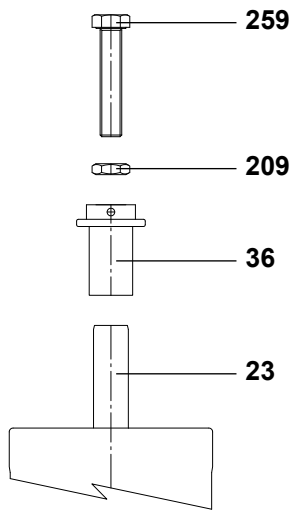

Dismantlement of stroke limiter in inlet
 Unscrew the screw (259) and remove the mechanical stop (36) from the upper shaft (23).

Assembly of stroke limiter in inlet
 Screw on the mechanical stop (36) the screw (259) and the nut (209). Lock the screw (259) on the shaft (23). Adjust the inlet with the mechanical stop (36) and block it with the nut (209).

Dismantlement of stroke limiter in outlet
 Unscrew the nut (209) and the screw (259), unscrew the screws (25) and remove the mechanical stop (36) from the upper shaft (23).

Assembly of stroke limiter in outlet
 Assemble the mechanical stop (36) on the cylinder (9) with the screws (25). Screw on the mechanical stop the screw (259) with the nut (209). Make the regulation with the screw and then block the nut (209).

SHAFT STROKE LIMITER IN INLET

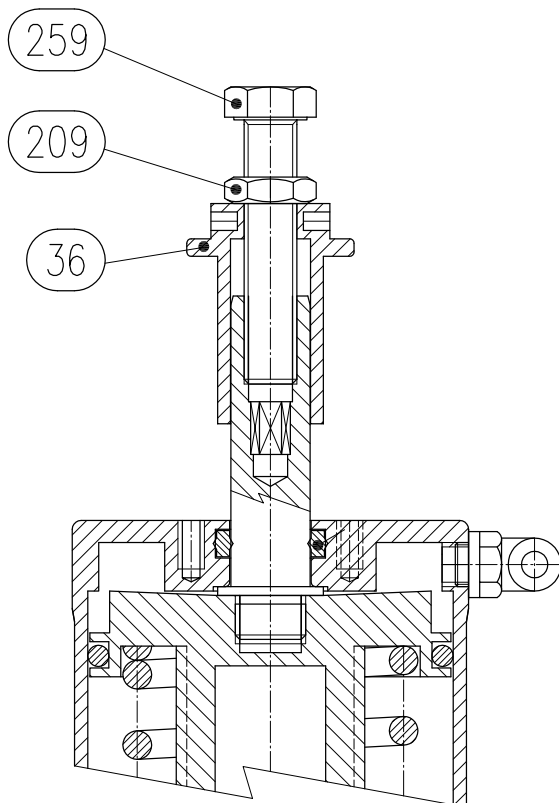

SHAFT STROKE LIMITER IN OUTLET

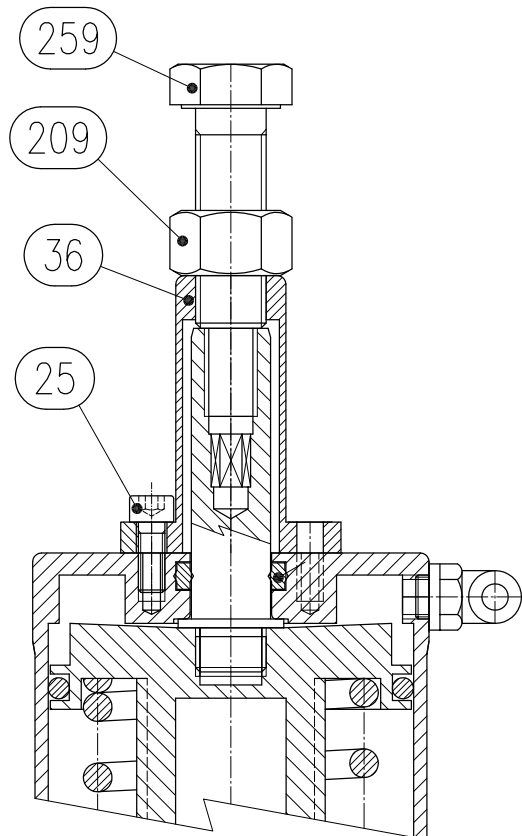

16. Technical Data

Valve Specifications:

Max. working pressure : 10 bar (145 psi)

Min. working pressure : Full vacuum

Max. product temperature : 120° C (248° F)

Min. product temperature : -10° C (14°F)

Material in contact with the product : AISI 316L (1.4404)

Gasket in contact with the product (FDA homologation) : EPDM, FKM, MVQ(silicon), HNBR (other seals available upon request).

Finish on surfaces in contact with the product : Ra 0.8 µm (other types of surface finish upon request).

Pneumatic Actuator Specifications:

Connectors : 1/8" (BSP)

Air Pressure : from 6 bar (87 psi) to 8 bar (116 psi)

Material : AISI 304L (1.4307)

Gasket Material : NBR

Power Supply (Giotto-Top®) : See Giotto-Top® Instruction manual

PED Directive 97/23/EEC, with special reference to Annex III, Module A regarding internal production control as Conformity Assessment Procedure in force

(valve sizes DN15--25 are not included in accordance with Article 3 paragraph 1.3:

Valves intended for gases, liquified gases, gases dissolved under pressure, vapours and those liquids whose vapour pressure at the maximum allowable temperature is greater than 0,5 bar above normal atmospheric pressure (1013 mbar) within the following limits:

- For fluids in Group 1 with a DN greater than 25
- Valve size DN125--150 only for fluids in Group 2)

17. Part List

Item	Description	Item	Description
4	Sealing ring	179	Grub screw
9	Cylinder	205	Nut
10	Bush	209	Nut
11	Shaft	232	Butterfly indicator
13	Piston	259	Socket screw
16	Sealing ring		
18	Threaded plug		
19	Sealing ring		
20	Lock wire		
23	Upper shaft		
24	Air fitting		
25	Socket screw		
31	Spring		
36	Mecchanical stop		
40	Plug		
41	Pin		
77	Nut		
97	Bush		
98	Insert		
110	Bolt		
133	Butterfly		
134	Gasket		
135	Support		
137	Bolt		
139	Half bodies		
149	Socket screw		
150	Threaded plug		
158	Pipe		
178	Sealing ring		

Warranties

1. CONTRACTUAL WARRANTIES AND LIABILITY

1.1 Bardiani Valvole S.p.A. warrant that their products are free from defects in design, material and workmanship. Bardiani Valvole S.p.A. shall be liable should any such defects be found within 12 (twelve) months from the date of delivery of the products.

1.2 Any claim regarding defects and/or faults found in the products shall be notified in full and in writing to Bardiani Valvole S.p.A. within 8 (eight) days from the date they were found. Adequate documentation shall be provided as evidence of said defects at the time the claim is filed.

2. LIMITATION IN LIABILITY

2.1 Without prejudice to any statutory right of the Buyer, Bardiani Valvole S.p.A. shall be under no liability in respect of electric components or elastomers that are part of their products.

2.2 The Seller shall be under no liability in respect of defects/faults specified in the following points:

- defects and/or faults arising from failure to follow the instructions contained in the "Manual of Instruction for the Use and Maintenance of the Product" as to the use and storage of the products by the Buyer;
- defects and/or faults arising from fair wear and tear of the products or their parts or their components;
- defects and/or faults arising from repairs or interventions of the goods carried out by unauthorized or unqualified staff;
- defects and/or faults arising from misuse, accidents, negligence and abnormal working conditions caused by the Buyer.

3. WARRANTY

3.1 Bardiani Valvole S.p.A. shall, at their discretion, repair or replace the products that are acknowledged to be defective.

3.2 Should repair or replacement of the product or of its components occur, the parts returned shall become the property of Bardiani Valvole S.p.A. The relevant freight costs involved in the return of the goods or their components shall be entirely met by Bardiani Valvole S.p.A..

3.3 Under no circumstance shall Bardiani Valvole S.p.A. be liable to indemnify immaterial or indirect damages such as damages or consequential loss, whether loss of profit, loss of business, loss of business opportunities, loss of time, loss of goodwill and damage to corporate image, etc.

3.4 The performance of repair or replacement under the above warranty shall not entail any extension of the warranty period of 12 (twelve months), such term being unconditional.

3.5 No distributor, agent or staff to Bardiani Valvole S.p.A. is entitled to make any amendment, extension or addition to the above warranty.

Disclaimer

1. All the statements, indications and technical data listed in this document are based on technical tests carried out by Bardiani Valvole S.p.A.. However accurate and reliable, such tests do not reflect all possible circumstances under which the products may be used.

It is therefore advisable that the Buyer should always ascertain the suitability of the product in its application. The Buyer will be entirely liable for all risks and damages incurred by said products.

Bardiani Valvole S.p.A. are not liable for any accident, loss or damage incurred, whether they be directly or indirectly caused by the use or misuse of the products.

No further guarantees other than those stated in this document shall be granted.

2. All our customers are advised to consult our technicians as well as our offices who will supply all information pertaining the technical characteristics of our products.

3. The pictures contained in this document are intended to be general representations. They are not to be intended either legally binding or detailed representations of our products.

4. The data and statements listed in this document only refer to our standard products. They do not apply in any case to any tailor-made products that might have been purchased by the customers.

5. Bardiani Valvole S.p.A. are not liable for any defects or faults resulting from the incorrect installation of their products. Such installation is to be carried out in full compliance with the instructions contained in the "Manual of Instructions for the Use and Maintenance of the Product". Bardiani Valvole S.p.A. are not liable for any defects or faults resulting from the incorrect use of their products.

6. Bardiani Valvole S.p.A. are not liable for any defects or faults resulting from the incorrect transportation and/or incorrect storage and/or incorrect maintenance of their products.

7. Bardiani Valvole S.p.A. cannot accept any liability for any faults or damages deriving from mishandling of the products and/or interventions carried out by unqualified personnel. No liability is accepted for damages caused by hits, dents, carelessness, negligence or any other any acts that cannot be considered as construction faults or faults related to the materials used in production.

